

Pro Series

DK4100 and DK5100

INSTRUCTIONAL MANUAL

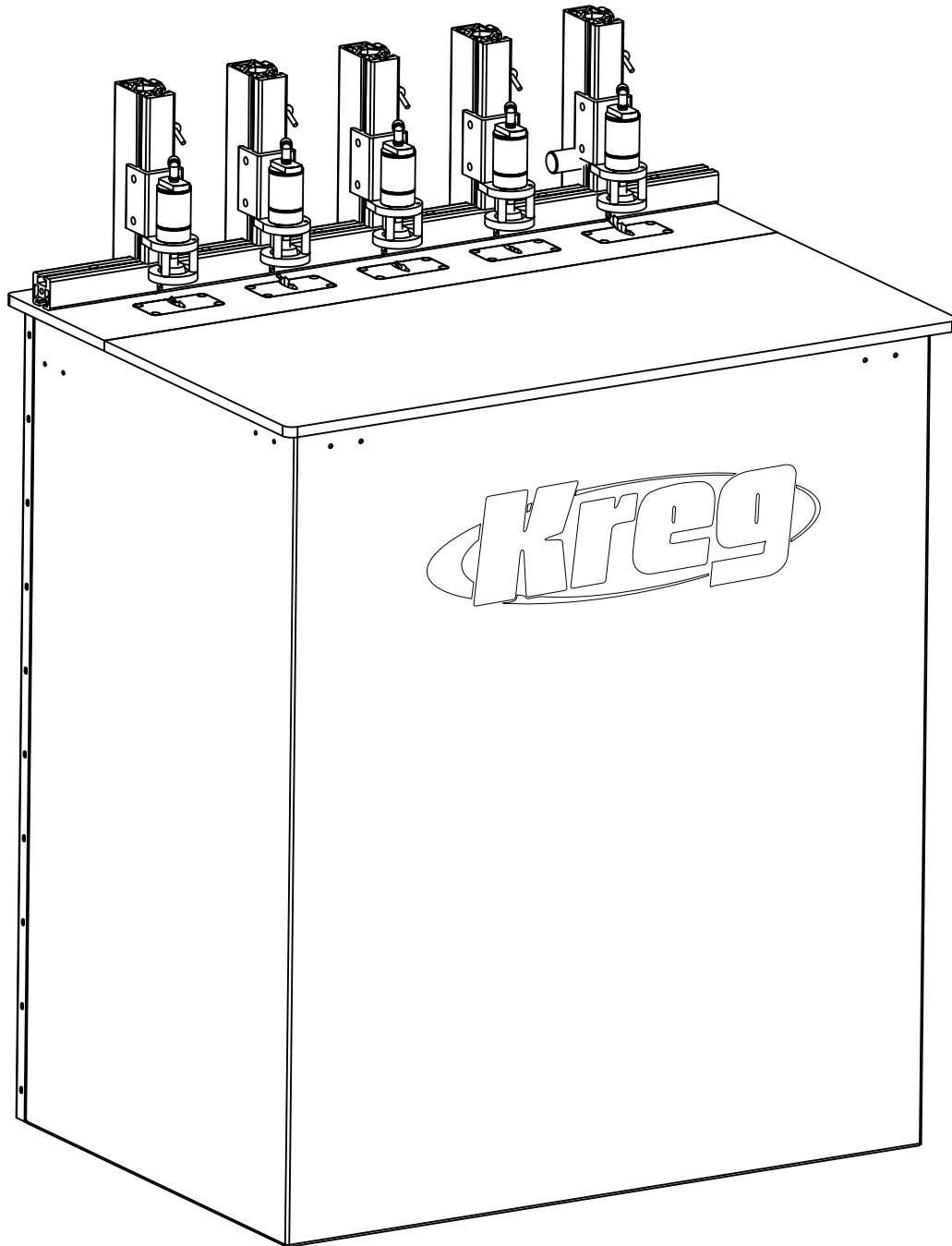

 *The Blue Mark of Quality.*

DK5109

20041101

Congratulations on choosing a Kreg Pro Series Pocket Hole Machine!

Be sure to read the instructions and the safety warnings completely before using this machine.

Table of Contents

<i>TABLE OF CONTENTS</i>	<i>1</i>
<i>SAFETY INSTRUCTIONS</i>	<i>2-3</i>
<i>PARTS DIAGRAMS</i>	<i>4</i>
<i>DK4100 and DK5100</i>	
<i>Changing Drill Bits</i>	<i>5</i>
<i>Adjusting the Drill Bit Depth Stop</i>	<i>5</i>
<i>Drill Unit Selection</i>	<i>6</i>
<i>Swing Stops</i>	<i>6</i>
<i>Adjusting Clamping Cylinder Height</i>	<i>6</i>
<i>Feed Rate Flow Control</i>	<i>7</i>
<i>Clamping Duration Control</i>	<i>7</i>
<i>Air System Prefilter</i>	<i>7</i>
<i>Air System Lubricator</i>	<i>7</i>
<i>Warranty</i>	<i>8</i>

 **Pro Series Safety Guidelines**

***Thank you for purchasing KREG Pro Series Pocket Hole Machine.
Please read and follow all safety guidelines to ensure safe
operation of this machine.***

Warning

- Woodworking machines are dangerous and can cause personal injury if not used properly.
- Read safety instructions and operating instructions for your machine completely before using products. Using this system before understanding its safe and proper use could result in serious injury to the operator.
- Warning: Failure to follow these rules may result in serious personal injury.
- For your own safety, read instruction manual before operating the tool. Learn the tools application and limitations as well as the specific hazards peculiar to it.
- Keep all guards and safety devices in proper place while using these products.
- Always wear safety glasses.
- Keep hands well away from the pneumatic clamp and rotating bit when operating machine.
- Avoid awkward hand positions, where a sudden slip could cause contact with rotating bit. Never reach under the pneumatic clamp pad with either hand to hold down the workpiece.

Kickbacks

Beware of kickbacks; they can cause serious injury. A kickback occurs when the workpiece binds up while being drilled, causing it to twist, jump, or become airborne.

To avoid kickbacks:

- Always use sharp drill bits.
- Keep machine in proper alignment and good working condition.
- Never perform any "free hand" drilling. Work must always be held securely against the table and fence.
- Always support longer boards when drilling.

Warranty

- Kreg components are fully guaranteed for one year from date of purchase.
- Kreg will replace or repair, at no charge to the customer, any product that fails within the warranty period.
- Kreg will service Kreg components beyond the warranty period at a reasonable cost to customer.
- Any neglect, misuse or usage of the Tools in a fashion not recommended by Kreg will void all warranties.

As with all machinery, there are certain hazards involved with operation and use of the machine. Using the machine with respect and caution will considerably lessen the possibility of personal injury. However, if normal safety precautions are overlooked or ignored, personal injury to the operator may result.

This system was designed for certain applications only. Kreg strongly recommends that this system NOT be modified and/or used for any application other than for which it was designed. If you have any questions relative to its application, DO NOT use the Tools until you have written Kreg Tool and we have advised you.

Safety Guidelines

To avoid injury, never adjust the fence, swing stop, clamping cylinder, depth stop or drill bit while machine is running.

Make sure drill comes to a complete stop before removing or securing workpiece, or workpiece angle.

Ground all tools. If tool is equipped with three-prong plug, it should be plugged into a three-hole electrical receptacle. If an adapter is used to accommodate a two-prong receptacle, the adapter lug must be attached to a known ground. Never remove the third prong.

Remove adjusting keys and wrenches. Form habit of checking to see that keys and adjusting wrenches are removed from tool before turning it "on".

Don't use in dangerous environment. Don't use power tools in damp or wet locations, or expose them to rain. Keep work area well-lighted.

Keep children and visitors away. All children and visitors should be kept a safe distance from work area.

Make workshop CHILD PROOF with padlocks, master switches, or by removing starter keys.

Don't force tool. It will do the job better and be safer at the rate for which it was designed.

Use right tool. Don't force tool or attachment to do a job for which it was not designed.

Wear proper apparel. No loose clothing, gloves, neckties, rings, bracelets, or other jewelry to get caught in moving parts. Nonslip foot wear is recommended. Wear protective hair covering to contain long hair.

Secure work. Use clamps or a vise to hold work when practical. It's safer than using your hand and frees both hands to operate tool. Don't overreach. Keep proper footing and balance at all times.

Maintain tools in top condition. Keep tools sharp and clean for best and safest performance.

Follow instructions for lubricating and changing accessories.

Disconnect tools before servicing and when changing accessories such as bits, clamps, etc.

Use recommended accessories. The use of improper accessories may cause hazards.

Avoid accidental starting. Make sure switch is in "OFF" position before plugging in power cord.

Never stand on tool. Serious injury could occur if the tool is tipped or if the cutting tool is accidentally contacted.

Check damaged parts. Before further use of the tool, a guard or other part that is damaged should be carefully checked to ensure that it will operate properly and perform its intended function. Check for alignment of moving parts, binding of moving parts, breakage of parts, mounting, and any other conditions that may affect its operation. A guard or other part that is damaged should be properly repaired or replaced.

Never leave tool running unattended. Turn power off. Don't leave tool until it comes to a complete stop.

Drugs, alcohol, medication. Do not operate tool while under the influence of drugs, alcohol or any medication.

Make sure tool is disconnected from power supply while motor is being mounted, connected or reconnected.

 **KREG TOOL COMPANY**
201 Campus Drive
Huxley, Iowa 50124

www.kregtool.com

800.447.8638

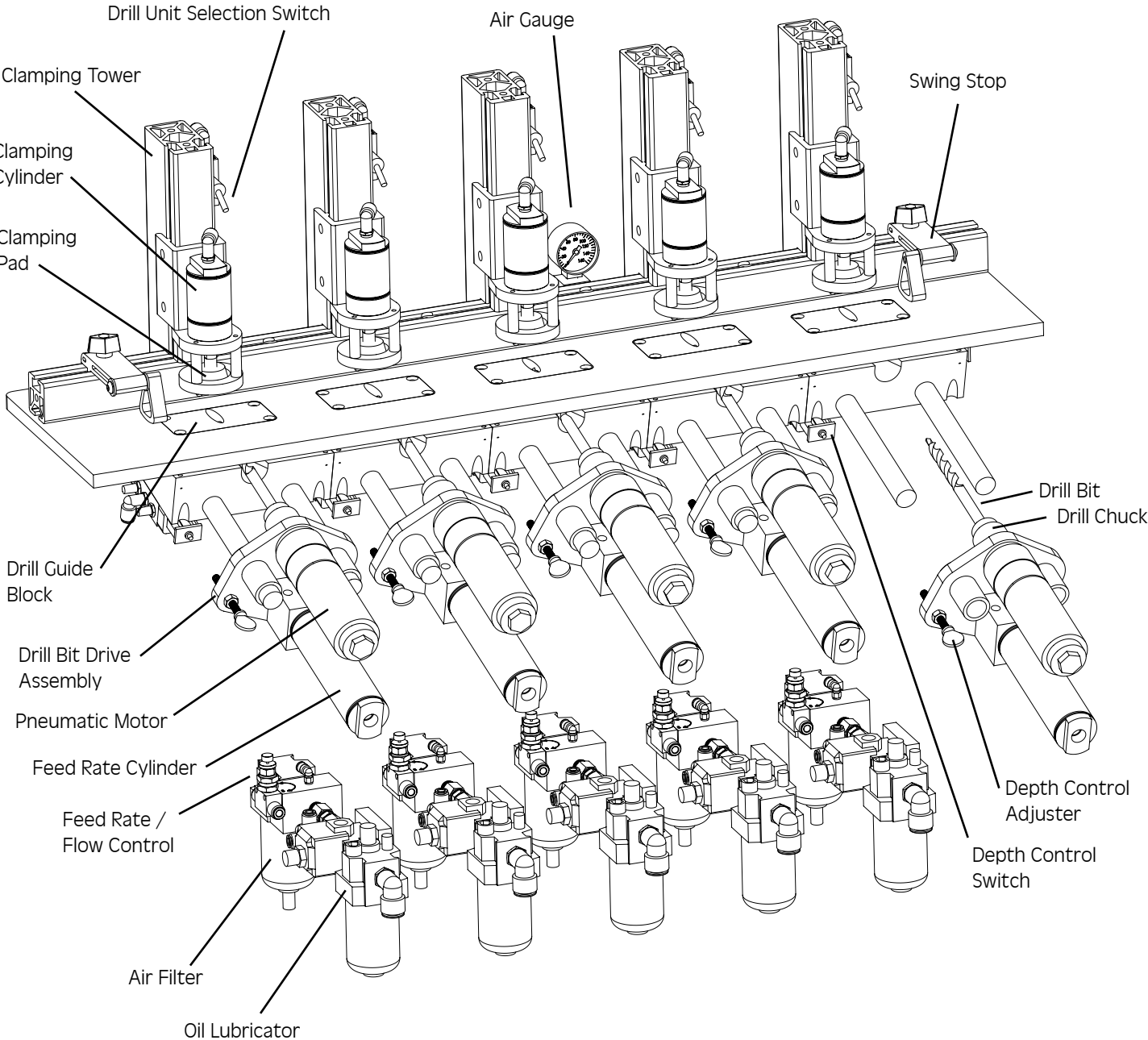

Changing Drill Bits

You can expect to drill between 4000 and 5000 holes in Oak with your #DKDB drill bit before the bit will need to be sharpened. This baseline was established using the factory settings described in the owner's manual. Adjust your sharpening schedule for your settings and the material that you may be drilling.

IMPORTANT !

Before changing the drill bit, make certain your machine is DISCONNECTED from the AIR SUPPLY. Cycle the machine via the foot switch several times to remove air from the system. Without an air supply you can be certain the bit will not accidentally engage while you are performing maintenance.

- Step 1:** Disconnect the machine from the air supply.
- Step 2:** Remove the Top Plate to gain access to the inside of the machine.
- Step 3:** Use the Chuck Key to open the Drill Chuck jaws.
- Step 4:** Remove the Drill Bit by pushing forward out of the Drill Chuck and into the Drill Guide Plate until the Drill Bit clears the Drill Chuck. Angle the Drill Bit slightly and pull clear of the Drill Guide Plate.
- Step 5:** Insert a new or re-sharpened Drill Bit into the Drill Chuck, aligning the flats on the Drill Bit shank with the jaws of the Drill Chuck.
- Step 6:** Insert the Chuck Key into EACH hole of the Drill Chuck and tighten EACH jaw of the Drill Chuck to maintain equal pressure on the Drill Shaft.

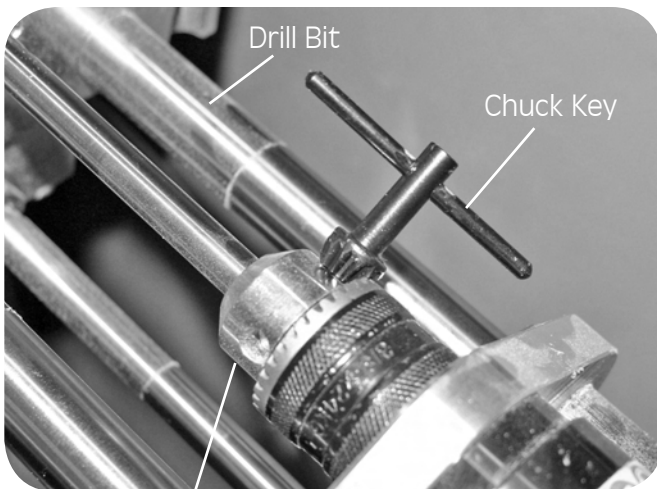

Drill Chuck

Adjusting the Drill Bit Depth Stop

A Drill Bit Depth Stop is provided to stop the Drill Bit forward motion and control the Drill Feed Cylinder cycle. When the head of the Drill Bit Depth Stop fully engages the Depth Control Switch the forward motion of the Drill Bit is stopped and reversed to complete the drilling cycle. Before adjusting the Drill Bit Depth Stop make certain your machine is DISCONNECTED from the AIR SUPPLY. Cycle the machine via the foot switch several times to remove air from the system. Without an air supply you can be certain the machine will not accidentally engage while you are performing maintenance. The Depth Control Adjuster should be adjusted so that the pilot point of the Drill Bit is just slightly away from the Fence when the Head has fully depressed the plunger on the Depth Control Switch. Make sure the Depth Control Adjuster is locked into position with the Lock Nut.

- Step 1:** Loosen the Lock Nut on the Depth Control Adjuster. Adjust the Depth Control Adjuster the approximate position.
- Step 2:** Push the Drill Bit Drive Assembly forward till the Drill Bit pilot point is slightly away from the Fence.
- Step 3:** Adjust the Drill Depth Control Adjuster till the Head fully depresses the plunger on the Depth Control Switch.
- Step 4:** Tighten the Lock Nut to lock the Depth Control Adjuster in position.
- Step 5:** Pull the Drill Bit Drive Assembly back into the resting position.

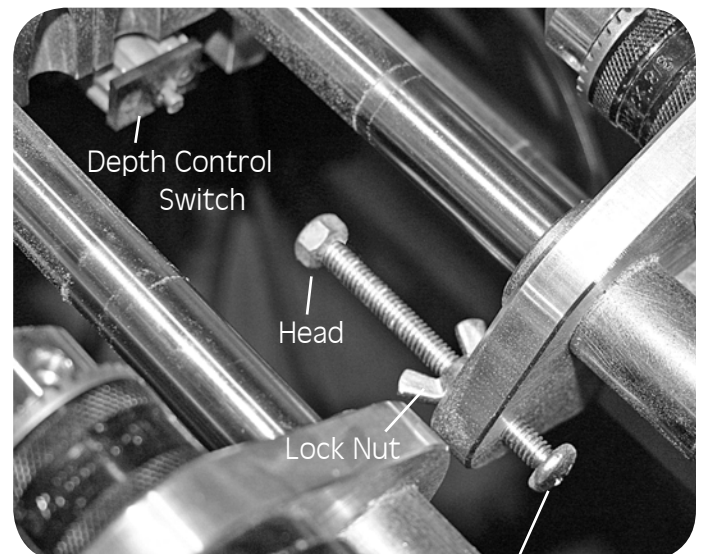

Depth Control Adjuster

Drill Unit Selection

The DK4100 and DK5100 machines were designed for multiple pocket hole drilling for applications normally associated with carcass construction. The DK4100 will drill up to four pocket holes at 8-inch centers across a 24-inch span. The DK5100 will drill up to five pocket holes at 6-inch centers across a 24-inch span. Each of the Drill Units can be independently selected via the Drill Unit Selector Switch. This simple "ON/OFF" switch will enable or disable the associated Drill Unit's operation. By selecting Drill Units to "OFF" that Drill Unit will not actuate during the drilling cycle. This option will allow the operator to vary the pocket hole spacing in increments of 6-inch and 8-inch spacing depend on the model. For example: two pocket holes may be drilled spaced 8-inches apart on the end of a 12-inch wide shelf by switching two Drill Units to "OFF" on a DK4100 machine. Another example would be to drill four pocket holes in a 28-inch panel with two holes spaced 2-inches from the each end and 6-inches apart by switching the middle Drill Unit to "OFF" on a DK5100 machine.

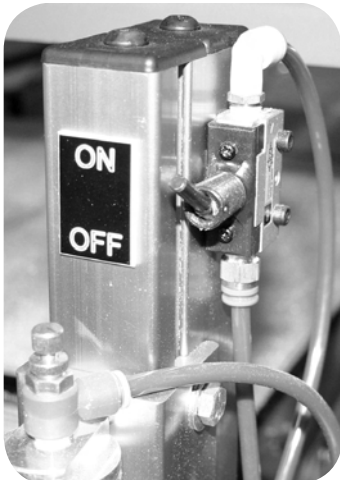

Adjusting the Clamping Cylinder Height

The Clamping Cylinder can be adjusted for material of different thicknesses. The factory setting will clamp materials of approximate thicknesses between 1/2" and 3/4". For materials thicker than 7/8", the Clamping Cylinder will need to be moved upward to allow the material to locate below the Clamp Pad. Before adjusting the Clamping Cylinder make certain your machine is DISCONNECTED from the AIR SUPPLY. Cycle the machine via the foot switch several times to remove air from the system. Without an air supply or electrical supply you can be certain the Clamping Cylinder will not accidentally engage or the drill bit will not rotate while you are performing maintenance.

- Step 1:** Loosen the (4) Socket-head Cap Screws (two on each side) located on the Clamping Cylinder Bracket.
- Step 2:** Adjust the Clamping Cylinder to allow the material to pass under the Clamp Pad.
- Step 3:** Tighten the (4) Socket-head Cap Screws to lock the Clamping Cylinder in position.

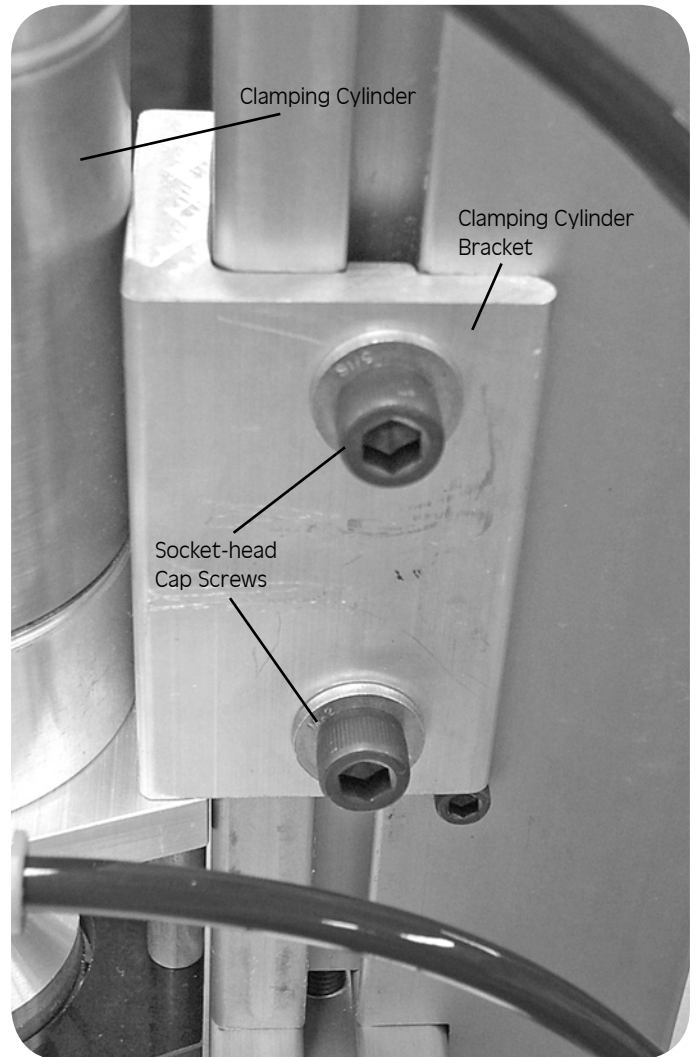

Swing Stops

Two Swing Stops are provided to assist in drilling pocket holes in the same location on multiple work pieces of the same dimension. When the Swing Stop is not used, it will pivot out of the way to allow the work piece to slide underneath and rest against the fence. To change the location of the Swing Stop simply loosen the Knob, move to the new location and tighten the Knob to lock the Swing Stop in position.



Feed Rate Flow Control

The Feed Rate Control Valve allows the user to adjust the speed at which the drill bit advances into the material. The factory setting of this valve will maintain a consistent feed rate for various thicknesses of different materials to optimize Drill Bit life. The Feed Rate Control Valve should only be adjusted when a faster or slower rate of Drill Bit feed is desired. This adjustment is only recommended for experienced users that consistently drill the same thickness of the same type of material on a daily basis. The Feed Rate Control Valve is adjusted by loosening the Locking Collar and rotating the Screw in the direction of the desired change in feed rate. "F" corresponds to a Faster feed rate, "S" corresponds to a Slower feed rate. Make certain to tighten the Locking Collar to prevent the Screw from accidentally drifting or vibrating out of adjustment

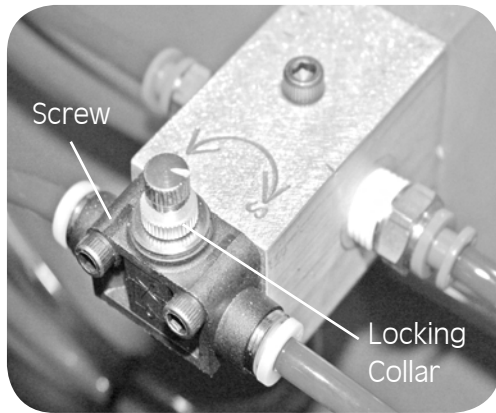

Clamping Duration Control

Clamping Duration Control allows the user to adjust the duration that the pneumatic clamp engages the material before, during, and after the drilling operation is performed. The factory setting of this valve will maintain the correct amount of time that the material is clamped while drilling. If the work piece lifts off of the Drill Guide Plate during drilling then the Clamping Duration Control will need to be adjusted. Loosen the Locking Collar and turn the Screw in the clockwise direction to increase the duration (more clamping time). Turning the Screw in the counter-clockwise direction decreases the duration (less clamping time). Make certain to tighten the Locking Collar to prevent the Screw from accidentally drifting or vibrating out of adjustment.

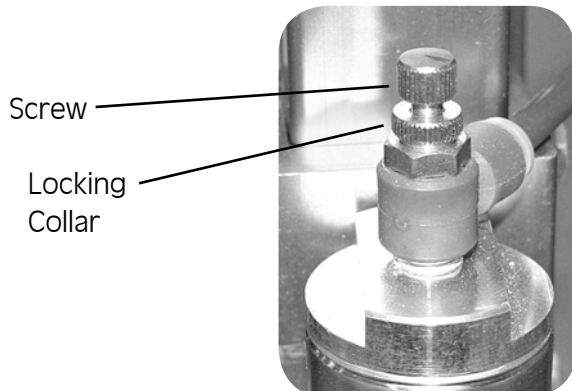

Air System Prefilter

An Air System Prefilter is provided to maintain a clean, moisture-free supply of compressed air to the machine. The Air System Prefilter reservoir should be routinely drained of moisture. To drain moisture from the reservoir either push the drain valve up toward the reservoir or to the side to use system air pressure to drain the collected fluid. If the Air System Prefilter reservoir needs to be removed to clean or replace the filter, make certain your machine is DISCONNECTED from the AIR SUPPLY. Cycle the machine via the foot switch several times to remove air from the system.

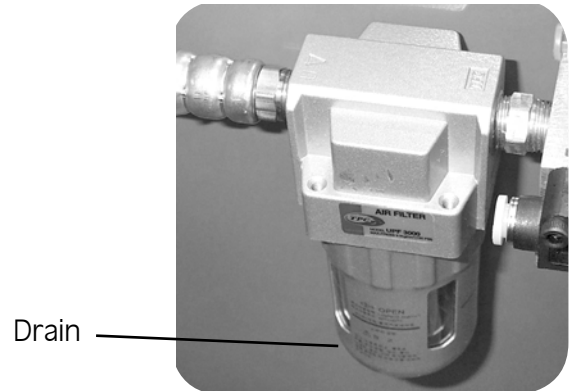

Air System Lubricator

An Air System Lubricator is provided to maintain proper lubrication to the pneumatic motors. The Air System Lubricator is filled with air motor oil and the Air System Lubricator comes preset at 1/2 turn open. The oil level in the Air System Lubricator should be routinely checked and refilled with air motor oil comparable to the oil provided. Normal use of the machine will cause a light film of oil to accumulate on the underside of the Top Plate where the pneumatic motor exhausts. Make certain your machine is DISCONNECTED from the AIR SUPPLY when filling the Air System Lubricator. Cycle the machine via the foot switch several times to remove air from the system.

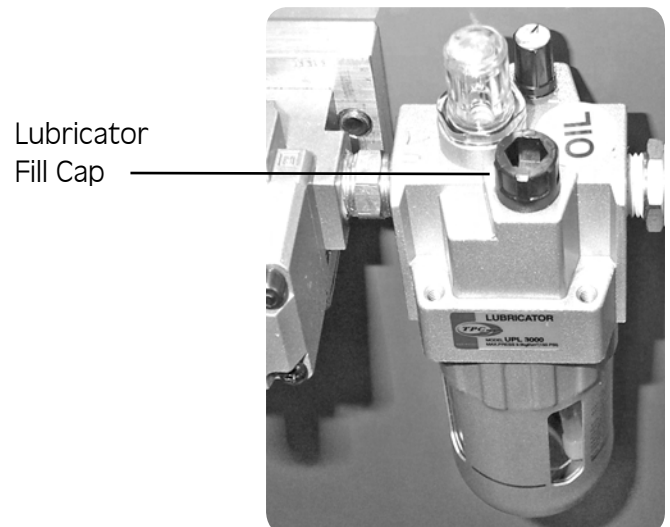

WARRANTY

DK SERIES - FULLY AUTOMATIC POCKET HOLE MACHINES

Kreg Tool Company warrants to its authorized distributors of Kreg products and the original purchasers from such distributors, the #DK5100/#DK4100 Pocket Hole Boring Machine to be free of defects in materials and workmanship for a period of one (1) year from the date of delivery to the original purchaser. During said warranty period Kreg will, at its option, repair or replace any product (or component part thereof) proving defective during said period. This warranty applies only to products which are used in accordance with all instructions as to operation, maintenance and safety set forth in catalogs, manuals, and/or instruction sets furnished by Kreg Tool Company.

This warranty becomes effective only if the accompanying card is fully and properly completed and returned to Kreg Tool Company within ten (10) days from date of delivery to the original purchaser.

The drill guide will carry a lifetime warranty.

This warranty does not apply to items that would normally be consumed or require replacement due to normal wear (drill bits, lubricants, etc.); for the cost of removal of components if such removal is authorized by Kreg Tool Company; for shipment to Kreg Tool Company's repair facility; or for reinstallation.

This warranty is null and void if the product has been subjected to (1) misuse, abuse or improper service or storage; (2) accident, neglect, damage or other circumstances beyond Kreg Tool Company's control; (3) modifications, disassembly, tampering, alterations or repairs outside of Kreg Tool Company's factory not authorized by Kreg Tool Company; (4) to any product not bearing its original serial number plate; and (5) for non-original purchasers. This warranty does not apply to normal wear and tear, corrosion, abrasion, or repairs required due to natural causes or acts of God.

To obtain warranty service contact the distributor from which the #DK4100/#DK5100 Pocket Hole Boring Machine was purchased, or you may contact Kreg Tool Company directly. Proof of purchase will be required before remedy will be provided under the terms of this warranty. Kreg Tool Company assumes no responsibility for products which are returned without prior authorization. Kreg Tool Company's obligations under this warranty shall be exclusively limited to repairing or replacing (at Kreg Tool Company's option) products which are determined by Kreg Tool Company to be defective upon delivery at Kreg Tool Company's factory, and on inspection by Kreg Tool Company. Under no circumstance shall Kreg Tool Company be liable for incidental or consequential damages resulting from defective products, nor shall Kreg Tool Company's liability exceed the purchase price paid for the product by the original purchaser.

This is Kreg Tool Company's sole warranty. Any and all other warranties which may be implied by law, including any warranties for merchantability or fitness for a particular purpose, are hereby limited to the duration of this warranty. Kreg Tool Company shall not be liable for any loss, damage or expense directly or indirectly related to the use of its products or from any other cause or for consequential damages (including without limitation, loss of time, inconvenience, and loss of production). The warranty contained herein may not be modified and no other warranty, expressed or implied, shall be made by or on behalf of Kreg Tool Company.

***Please register your warranty by sending warranty registration card.
Warranty service will not be provided without registration.***

Keep this form for your records.

For your records the following information will be useful in the event warranty service is required. For complete records attach copy of purchase invoice to this form.

Date of Purchase: ___/___/___

Purchased From: _____

Serial Number: _____

(serial number is located on the caution label applied to the outside of the machine)



Kreg Tool Company 201 Campus Drive Huxley, IA 50124